

FESTEL CAPITAL

Dr. Gunter Festel
Schuermattstr. 1, CH-6331 Huenenberg
Phone +41 41 780 1643
Mobile +41 796 527 112
Email gunter.festel@festel.com



Drinking Water Extraction from Air

Summary

Desorption and condensation process for the extraction of drinking water from atmospheric air through adsorbents.

The adsorber system of compact design and continuous operation yields 10 times more water than previous technologies.

Through the choice of adsorbents, the system can be optimally adjusted for the corresponding climate characteristics.

Requires little energy and can be combined with various energy sources.

Industrial partners and financial investors are sought for various possible commercialisation options.

Background

In the ambient air water is dissolved depending on temperature and pressure. Water-loaded air is a worldwide existing resource which has an inexhaustible potential. Technical possibilities for water trapping from air are already known from climate technology. A process has been developed, in which the humidity contained in the atmospheric air is bound by adsorbents and is later extracted as drinking water by means of desorption and condensation. FESTEL CAPITAL is supporting a German university to commercialise this innovative technology, a patent for which has been granted in Europe, all Arabic speaking countries, and 30 countries worldwide

Description

The core of this process for drinking water extraction from air is a rotary adsorber system whereby the novelty lies in the choice of adsorbents as well as in the process control.

Working principle

The air is sucked in from the environment by a ventilator and is rid of oil and sand by a filter, if necessary. Afterwards the air stream is led to the rotary adsorber system which is filled with solid adsorbents to absorb the air's humidity. Then the dried air leaves the plant. On the opposite side the hot air passes through the rotary adsorber system, which takes up the water. From this hot air stream, which is less than the other air stream, the contained water can be separated by a simple air cooler which works at ambient temperature. By adjustment of the rotor revolutions the plant can be adapted to the different water capacity of the air streams locally available. The cycles of the ad- and desorption can easily be varied.

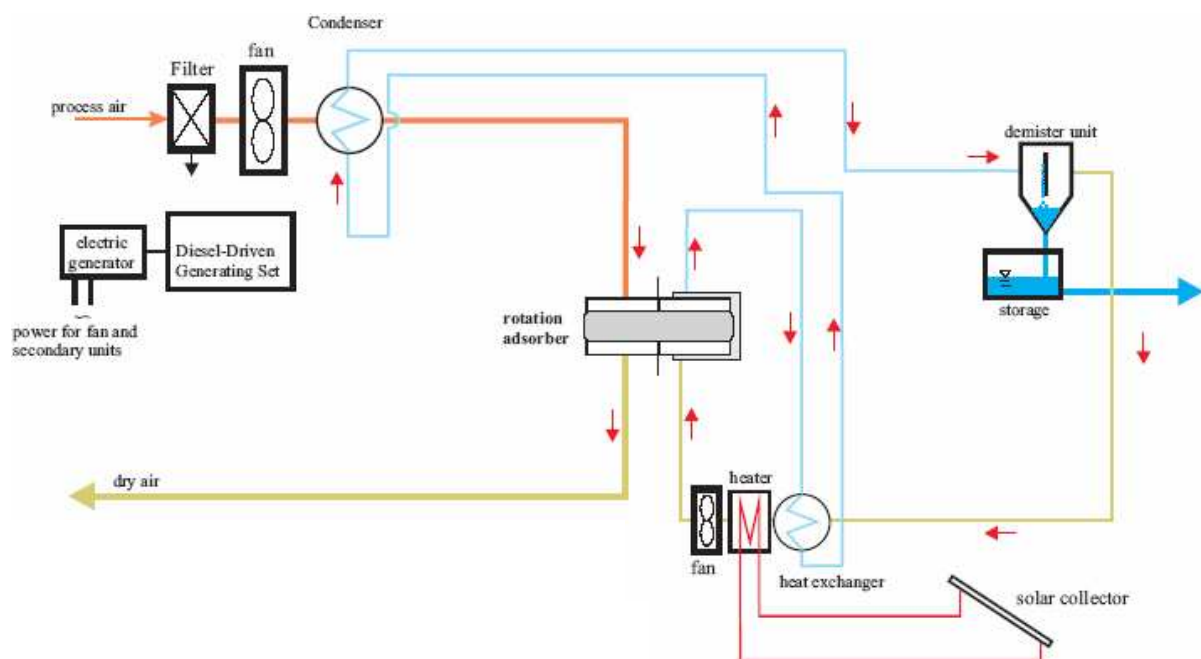

Block diagram of a drinking water extraction plant with solar energy supply

Choice of adsorbents

The choice of the adsorbents depends on the relative humidity of the air which in turn is determined by the climate of the countries interested. As adsorbents, porous solid particles are used which show a high capillarity of different diameters (r_c). The inner surface of these particles is approx. 500 m/g solid. Every relative humidity of air can be attributed a maximum capillary radius (r_{cmax}), up to which all smaller capillaries are filled with water by condensation. By choosing the corresponding adsorbent it is possible to fill the capillaries completely and the continuous change between adsorption

and desorption can be carried out at the peak load. This way 10 times more water can be extracted as opposed to previously.

Advantages

- Optimally adjustable to the climate characteristics through choice of adsorbent to the relative climate characteristics.
- In comparison with traditional technologies, this system is much smaller in its dimensions and also allows a continuous operation.
- Only little energy is needed at a maximum water adsorption (effect of the capillary condensation).
- Skilful control of the air stream makes it possible to retrieve most of the spent energy.
- The process concept can be combined with different energy sources.

Investment Opportunity

The aim of FESTEL CAPITAL is to commercialize this innovative (drinking) water processing technology. In the search for industrial partners and financial investors different commercialization options, such as founding a dedicated start-up company, out-licencing or a sale of all relevant intellectual property and know-how, are possible. Detailed information can be provided after the signing of a confidentiality agreement.

Disclaimer

FESTEL CAPITAL has prepared this document to the best of FESTEL CAPITAL's knowledge and belief based on all available information. FESTEL CAPITAL takes no warranty for the accuracy and completeness of this information. Therefore, all liability for costs or damage resulting from information and conclusions in this document is excluded.

About FESTEL CAPITAL

FESTEL CAPITAL is an advisory and investment firm focusing on the commercialisation of technologies in the areas of energy, environment, health, materials and nutrition.

CONTACT: Dr. Gunter Festel, Schuermattstrasse 1, CH-6331 Huenenberg/Zug, Phone +41 41 780 1643, Mobile +41 796 527 112, E-Mail gunter.festel@festel.com.